



Financing Programme to Demonstrate Advanced  
Low-Carbon Technology Innovation for  
Further Deployment in Developing Countries

# Project Case Studies

## Table of Contents

Outline of Financing Programme to Demonstrate Advanced Low-Carbon Technology Innovation for Further Deployment in Developing Countries	..... 2
Development of an energy management system (EMS) to provide a stable supply of renewable energy	..... 3
Development and demonstration project of absorbing surplus energy from wind turbine generators with typhoon resistant system by mobile power pack in small scale islands of the Philippines	..... 6
Development of zero-emission electrical bus for Cat Ba Island in Viet Nam	..... 9
Energy saving for the de-greasing process of aluminum chips by utilization of superheated steam	..... 12
Establishment of bioethanol production system by utilizing unused biomass	..... 15
Low-head micro-hydro turbine power generation system for Indonesia cellular base transceiver stations	..... 18
Development of rice husk gasification CHP system	..... 21
Electricity retail service at kiosks in off-grid areas	..... 24
Cover photographs (photo credits from the top)	
<ul style="list-style-type: none"> <li>• Indonesia Demonstration site of energy management system (EMS) (Kyudenko Corporation)</li> <li>• Philippines Demonstrated wind turbines and electric motorcycles (Komaihaltec Inc.)</li> <li>• Viet Nam Demonstrated electrical bus (Soft Energy Controls Inc.)</li> <li>• Indonesia Demonstration facility for aluminum chip degreasing (Giko Corporation)</li> <li>• Philippines Demonstration site of bioethanol production (Nippon Steel &amp; Sumikin Engineering Co., Ltd.)</li> <li>• Indonesia Demonstration site of low-head micro-hydro turbine power generation system (Sinfonia Technology Co., Ltd.)</li> <li>• Myanmar Demonstration site of rice husk gasification CHP system (Yanmar Co., Ltd.)</li> <li>• Tanzania A kiosk providing service of WASSHA system (WASSHA Inc.)</li> </ul>	

# Financing Programme to Demonstrate Advanced Low-Carbon Technology Innovation for Further Deployment in Developing Countries

## Background and purpose

- Developing countries have a significant need for advanced low-carbon technologies, and there is an international need to bolster international efforts to address global warming. Meanwhile, if low-carbon technologies are transferred to developing countries without being adapted to local circumstances, they might not be accepted in the market due to environmental regulations, cultural practices, and resource and energy constraints, etc.
- By significantly modifying these low-carbon technologies to adjust them for local characteristics in developing countries and promoting world-leading low-carbon technologies, this programme aims to expand the JCM,

realize a low-carbon society in developing countries, expand the technologies internationally, and at the same time reduce CO<sub>2</sub> emissions.

- Through innovations arising from these processes, this programme will also lead to further technological developments in Japan and expand to other regions.

## Programme outline

Relevant costs will be partially subsidized for private sector companies that engage in significant renovations of low-carbon technologies, based on a matching of companies that have advanced low-carbon technologies with the needs of developing countries, as well as the details of the renovations.

## Outline of Adopted Projects

- "Renewable, decentralized energy" accounts for majority of applied technologies.
- Indonesia, Thailand, and Viet Nam accounts for half of target countries.
- Thirty two projects were adopted during implementation period of this programme from FY2014 to FY2018 for five years.

Adopted projects classified by applied technologies

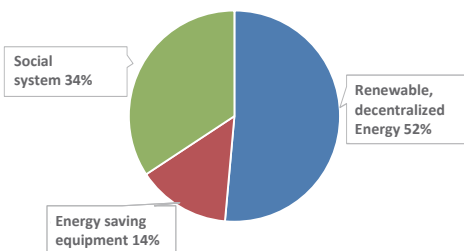

Adopted projects classified by target countries

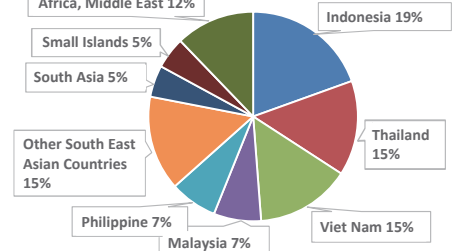

Social system	Energy saving equipment	Renewable, decentralized energy
<ul style="list-style-type: none"> <li>➢ Electric Vehicle, Electric motorcycle</li> <li>➢ Water supply, Waste water treatment</li> <li>➢ Desalination</li> <li>➢ Conversion of waste plastics to RPF</li> </ul>	<ul style="list-style-type: none"> <li>➢ Industrial equipment</li> <li>➢ LED lighting equipment</li> <li>➢ Energy management system (EMS)</li> <li>➢ Eco-drive System</li> </ul>	<ul style="list-style-type: none"> <li>➢ Solar, micro hydro, wind power generation</li> <li>➢ Biomass power generation, biofuel production</li> <li>➢ Bioethanol, biodiesel production</li> </ul>

## Target Countries of Case Studies

※ This case studies focuses eight model projects in terms of its business continuity and possibility of future dissemination

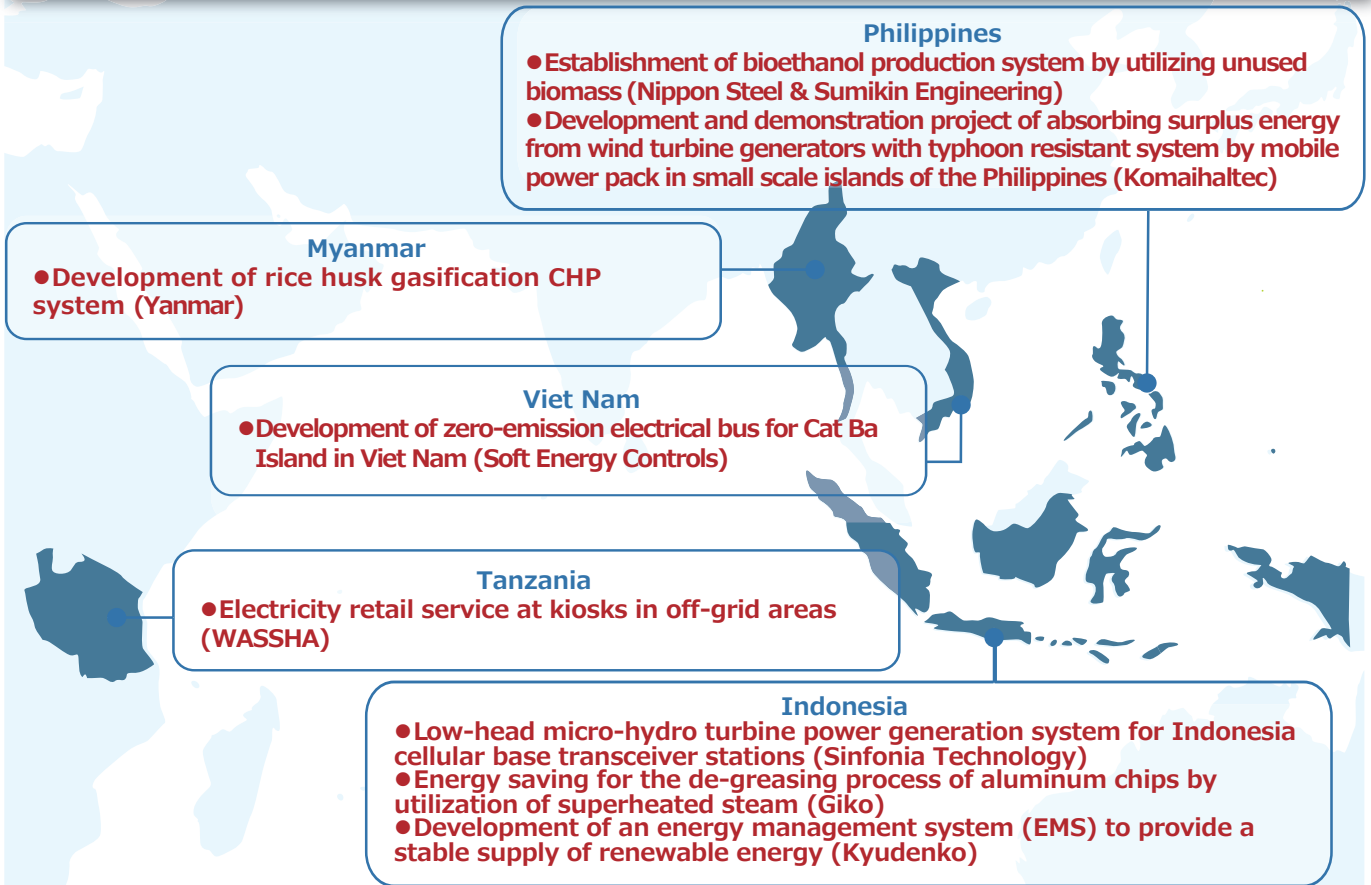

## Financing Programme to Demonstrate Advanced Low-Carbon Technology Innovation for Further Deployment in Developing Countries

<b>Country</b>	Republic of Indonesia
<b>Project</b>	Development of an energy management system (EMS) to provide a stable supply of renewable energy
<b>Company</b>	Kyudenko Corporation
<b>Period</b>	FY2016 – FY2018

### Outline of Project

#### [Purpose]

- The aim was to reduce CO<sub>2</sub> emissions by substituting renewable energy for existing diesel generators that now supply local power grids on the Indonesian island of Sumba.
- Also, at the Indonesian government's test facilities on Sumba Island, to demonstrate low cost energy management system that includes storage batteries with long life technology and an energy management system (EMS) that can be adapted to the local environment.

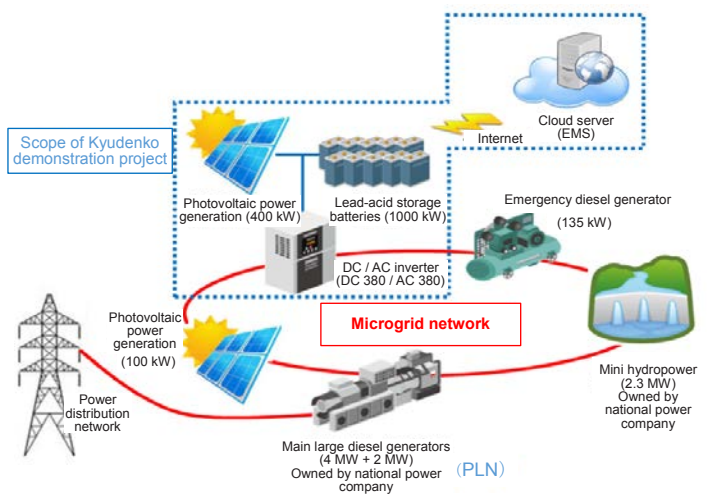

**Outline of demonstration project**

#### [Details of Technology Renovation & Demonstration]

- (1) Adaptation of a system (EMS and storage batteries) to the local environment and demonstration that the system is capable of providing a stable supply of electricity from various power sources, including renewable energy.
- (2) Extending the life and reducing the costs of lead-acid storage batteries.
- (3) Development of remote monitoring systems and maintenance/management systems linked with power generation sites.

### Outline of Target Country/Region

- To address power shortages, Indonesia has set a target of expanding the ratio of renewable energy in the power mix to 23% by 2020.
- Indonesia has many inhabited islands, making it difficult to distribute electricity through a trunk power transmission network, so local power grids are mainly supplied by diesel generators.
- Sumba has a population of approximately 600,000 and is located in the eastern part of the country. The Indonesian government has designated it as a model region for the introduction of renewable energy.



Map data © OpenStreetMap contributors  
www.openstreetmap.org/copyright

### Local Technology Needs

- Large diesel generators powered by heavy oil are the main source of electricity on Sumba. The photovoltaic power generation and storage batteries at power generation testing facilities



owned by the Indonesia government's Agency for the Assessment and Application of Technology (BPPT) in order to reduce the dependency on diesel-powered generators, but they do not have adequate performance for electricity supply/demand control and power storage control, so they were not able to provide a stable supply of electricity to local power grids on vulnerable islands from the uneven amount of electricity generated by renewable energy.

- Systems were needed that were capable of providing a stable supply of power from renewable energy and other power generation sources, and were also capable of providing remote monitoring and operation.

## Key Points of Technology Renovation

### (1) Creation of a power supply system adapted to the local environment

- By aggregating and creating big data in EMS subsystems from a variety of data about the power generation environment, it is now possible to simulate how to control an EMS in anticipation of sudden changes in electricity generation caused by weather conditions and sudden load fluctuations.

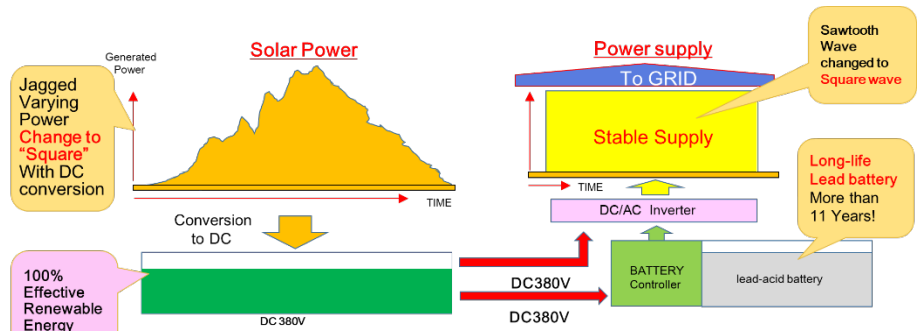

- With a hybrid system of renewable energy and lead-acid storage batteries, when the amount of electricity generated from renewable energy exceeds a certain level, by charging a storage battery it is now possible to supply electricity to the power grid from various electrical sources, including renewable energy. In this demonstration, photovoltaic power generation supplied 200 kWh over a period of 7 hours daily.

### (2) Longer life of lead-acid batteries

- By improving the charging/discharging technology, an effort was made to lengthen the life of lead-acid storage batteries to a predicted life of over 10 years. (The performance of typical lead-acid batteries declines after about 4 years.)

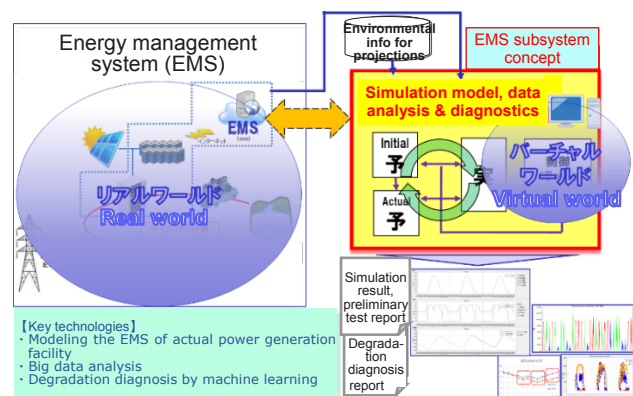

Outline of systems demonstrated by this project

### (3) Development of systems to remotely monitor and manage power generation status

- A network infrastructure was developed that can monitor the power generation status online from any location, and a system was developed to remotely monitor and support facility operations.
- An operating manual was developed for the remote monitoring system. Also, operation management of the power generation system, training of local human resources, and technical capacity building were being implemented.

## Results of the Project

### Summary of Results

- Succeeded in controlling the electricity generated from renewable energy by EMS and electricity storage technology and providing a stable supply of renewable energy-derived electricity to local grids.

- Improved lead-acid battery charging/discharging technology and achieved longer battery life (more than 10 years)
- Operated a remote monitoring system and established an operating and maintenance/management system linked with generation sites.

### Prospects for Commercialization & Diffusion

- Indonesia has 4,600 diesel generators\* connected to local power grids. More than 10% of them are expected to be replaced by 2030, so there is high expected demand for EMS to provide a stable supply of renewable energy to local power grids.

\* Source: PLN annual report

### Applying the Technology Back in Japan

- These technologies are expected to be used for regional microgrids that combine renewable energy and existing power generation facilities. This could help to address possible future challenges such as an increase in the number of marginal communities in Kyushu Electric Power Co., Inc.'s service area, as well as rising costs of electrical power generation from internal combustion.

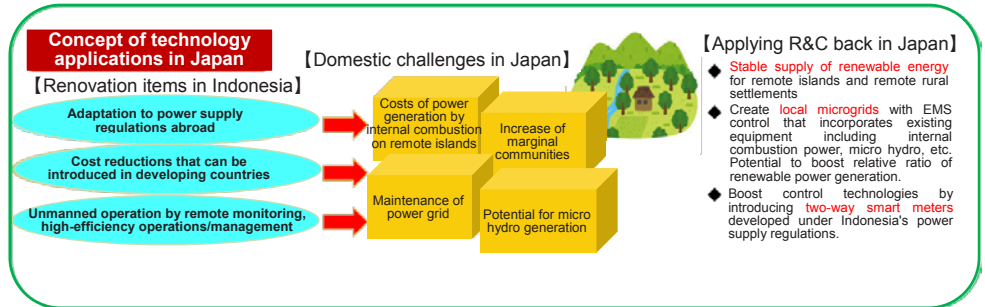

Concept of technology applications in Japan

# Financing Programme to Demonstrate Advanced Low-Carbon Technology Innovation for Further Deployment in Developing Countries

<b>Country</b>	Republic of the Philippines
<b>Project</b>	Development and demonstration project of absorbing surplus energy from wind turbine generators with typhoon resistant system by mobile power pack in small scale islands of the Philippines
<b>Country</b>	Komaihaltec Inc. (Project Participant: Honda Motor Co., Ltd.)
<b>Period</b>	FY2017 - FY2018

## Outline of Project

### 【Purpose】

- The aim of this project was to mitigate the output restriction of wind power generation on islands in the Philippines by connecting 300 kW medium-sized wind turbines suitable for island conditions, via a network to a battery charging station, and by using a control system to charge mobile batteries using surplus power from the wind turbines. Further reduction of CO<sub>2</sub> emissions is to be achieved by using the charged batteries mainly to power electric motorcycles.
- On islands in Japan, connecting renewable energy to the electrical grid is often constrained by grid capacity. This demonstration project also aimed to address local power demand and the operating environment for electric motorcycles, so it was conducted in the Philippines.

### 【Details of Technology Renovation & Demonstration】

- (1) Designed a system to utilize surplus electricity from wind turbines by using multipurpose battery packs.
- (2) Demonstrated typhoon-resistant design for wind turbines.
- (3) Demonstrate electric motorcycles for island use in Asia.

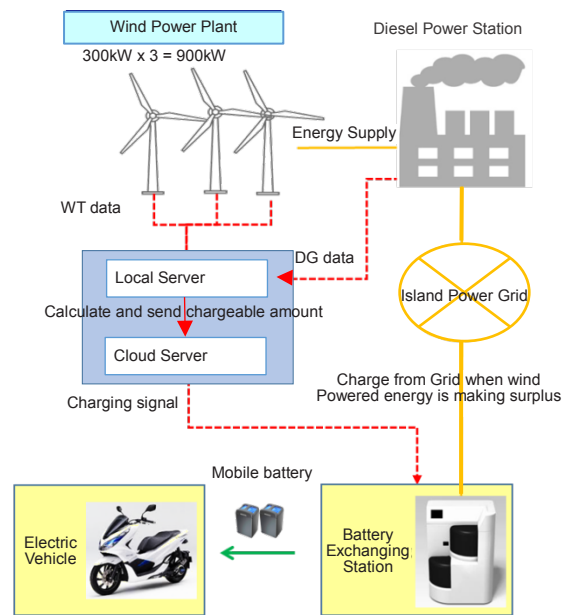

**Outline of demonstration project**

## Outline of Target Country/Region

- The Philippines have many small islands that rely on diesel fuel to generate electricity. The country currently has about 300 grids powered this way.
- The region has abundant wind resources. However, surplus electricity is one factor that must be addressed in order to effectively utilize renewable energy in small-scale power grids. Also, super-typhoons have occurred in recent years, so some measures are necessary to make wind turbines withstand strong winds.
- This project conducted a demonstration on Romblon, an island in the Philippines where motorcycles are the main mode of transportation for residents.

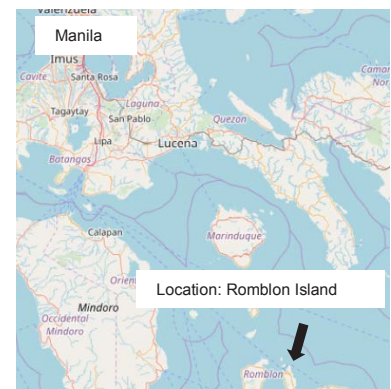

Map data © OpenStreetMap contributors  
www.openstreetmap.org/copyright

## Local Technology Needs

- Renewable energy is a fluctuating source of electricity, and the generation of surplus electricity is a major consideration when introducing this form of energy to small island power grids. Large wind turbines are generally excessive in scale relative to electricity demand and also pose more physical challenges for installation. The installation of storage batteries can lead to significant increases in project costs, while on the other hand, not installing them limits the amount of electricity that can be generated by a renewable energy generation system. Both cases lead to a decline in project viability, so systems are needed that can utilize this electricity effectively.
- Super-typhoons have been occurring in Asia, leading to increasing problems for wind turbines built to conventional specifications (typically able to withstand wind speeds of about 70 m/s).
- Motorcycles are the main means of transportation on islands, but fuel supplies rely on deliveries from off the island, are costly, and are vulnerable to weather conditions.

## Key Points of Technology Renovation

In the demonstration, 300 kW wind turbines capable of surviving a super-typhoon (wind speed of about 79.8 m/s) was installed. Constraints on electricity output were mitigated by connecting it via a network to a charging station capable of simultaneously charging up to six 1 kWh multi-purpose mobile batteries. The batteries were then used to power electric motorcycles.

### (1) Design of system to utilize surplus electricity from wind turbines by using multipurpose battery packs

- By consolidating multiple mobile batteries into one charging station, it is possible charge the batteries at any time, and this ensures their effectiveness in absorbing surplus electricity from wind power.
- A local and cloud-based control system instructs charging stations on the timing of charging based on the operating status of the wind turbine, the operating status of the diesel power plant(s) on the grid, and the status of charging stations.

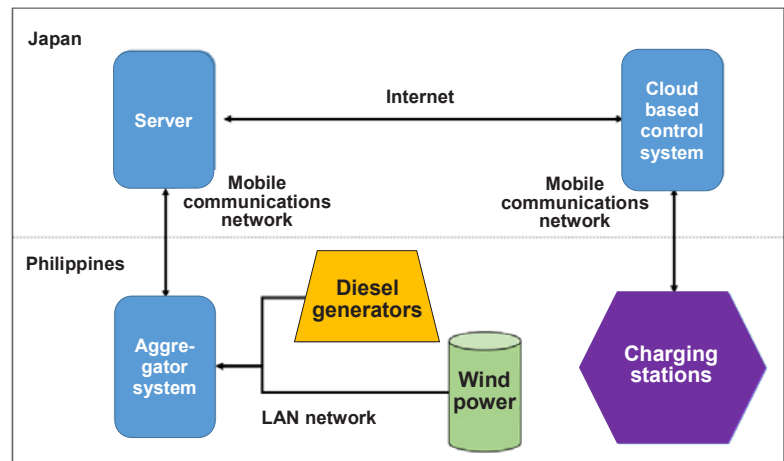

Overall concept of control system demonstrated to utilize surplus electricity

### (2) Demonstration of typhoon-resistant design for wind turbines

- The system was designed to keep the wind turbine facing downwind to increase its survival wind speed even during a power failure when there is no power from the grid to control the turbine.

### (3) Demonstration of electric motorcycles suitable for islands in Asia

- In addition to conventional designs for electric motorcycles, this project aimed to improve drivability on rough roads, to accommodate multiple riders, and to reduce user costs by utilizing removable mobile batteries.



Charging Station Units



## Results of the Project

### Summary of Results

- Three wind turbines were constructed, 17 battery charging station units were installed at 5 sites, the placement of all controlling devices was completed, and system operations were confirmed by total system testing.
- 100 electric motorcycles were provided (not covered by subsidy). It was confirmed that the motorcycles consumed more than the expected amount of 80 kWh per day, which can absorb the surplus electricity with batteries.
- Trials confirmed the electricity generation by wind turbines as well as the typhoon control system.

### Prospects for Commercialization & Diffusion

The systems is expected to be applied to small stand-alone electrical grids such as islands.

- Step 1: Expand this system based on achievements of this demonstration project. Consider the next sites to introduce the system.
- Step 2: Conduct design work for introduction to next sites.
- Step 3: Introduce the system at about two installations annually on Philippine islands.

## Applying the Technology Back in Japan

- The technologies and results demonstrated in this project can be expanded to any island region. Besides the Philippines, this technology is also appropriate for other islands in the Pacific and Asian regions in general. It is also expected to be applied on islands in Japan.

## Financing Programme to Demonstrate Advanced Low-Carbon Technology Innovation for Further Deployment in Developing Countries

<b>Country</b>	Socialist Republic of Viet Nam
<b>Project</b>	Development of zero-emission electrical bus for Cat Ba Island in Viet Nam
<b>Company</b>	Soft Energy Controls Inc.
<b>Period</b>	FY2015 – FY2016

### Outline of Project

#### **[Purpose]**

- The aim of this project is to reduce CO<sub>2</sub> emissions through reduction of diesel consumption by developing an electric vehicle (EV) route bus suited to the operating conditions on Cat Ba Island in Haiphong City, Viet Nam, with hilly terrain, high humidity, and high tourist traffic. Actual demonstration trials were conducted with a zero-emission EV bus and exchangeable batteries, using this company's battery control technology, combined with photovoltaic power generation.
- The use of exchangeable batteries enables the bus to travel longer distances without time constraints related to battery charging. The project adopted a CIGS photovoltaic generation system, which works well in the cloudy weather of northern Viet Nam, and will engage in business development in the region to promote the technology using renewable energy combined with storage battery packs.
- The demonstration was conducted in Viet Nam due to the need to demonstrate operations using lithium-ion batteries under the actual local climate and road conditions.

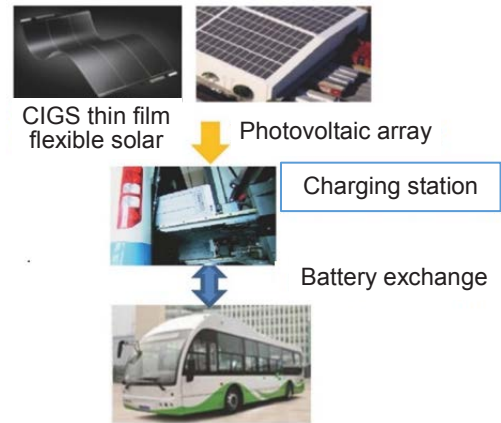

**Outline of demonstration project**

#### **[Details of Technology Renovation & Demonstration]**

- Adaptation of lithium-ion batteries to local climate conditions
- Measures to address salt damage affecting all equipment
- Adaptation to road conditions including hills and sharp curves
- Creation of a remote management system for batteries

### Outline of Target Country/Region

- Cat Ba is the largest island in the Halong Bay in Haiphong City, Viet Nam. Well known as a World Heritage Site, it attracts more than a million tourists annually.
- Cat Ba Island was designated as a UNESCO Biosphere Reserve in 2004 with abundant nature and ecosystem, but it is dealing with environmental problems due to a rapid increase in tourists. Thus, it is aiming to introduce environmentally-friendly transportation and renewable energy.

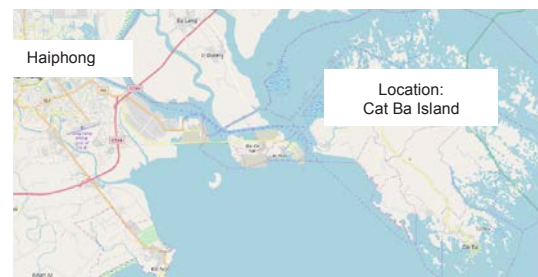

Map data © OpenStreetMap contributors  
www.openstreetmap.org/copyright

### Local Technology Needs

- With the expressway project to connect Hanoi and Cat Hai Island (neighboring Cat Ba), in order to protect the environment of the ecosystem-rich Cat Ba Island, there are also plans to prohibit ferry access to the island for passenger cars and diesel buses, so there will be a need to respond to the transportation needs of growing numbers of tourists to Cat Ba Island.

## Key Points of Technology Renovation

### (1) Adaptation of EV System for Local Environment

- For bus operation on long routes in a hot and humid climate and under steep and winding road conditions, it was decided to use high-power lithium-ion batteries and the lightest available bus body, with the used of exchangeable batteries that are suited to the operating conditions.
- Road trials confirmed that the bus can operate for 160 km of continuous driving, assuming a full capacity passenger load.

### (2) Creation of Remote Management System for Lithium-ion Storage Batteries

- For efficient bus operation, a remote battery management system was created that uses the local telephone company's communication network to collect and store data about the operating status of the battery system while the bus is running.
- A data communication system was developed that can collect information at regular intervals, such as GPS location information, battery levels, and other battery information such as voltage and current, and upload it to a server via the mobile phone network. Information on the server can be displayed remotely in real time.

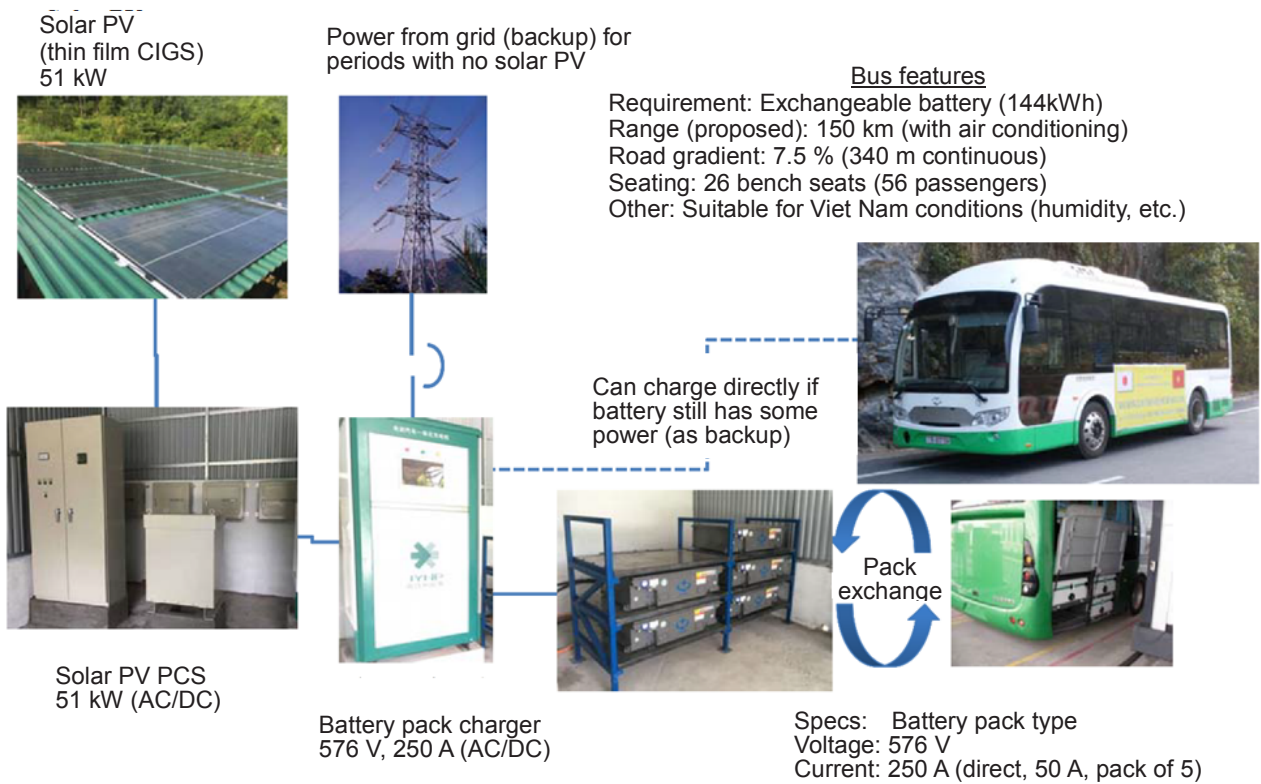

Outline of system demonstrated in this project

## Results of the Project

### Summary of Results

- Decided on the specifications for lithium-ion storage batteries suited to local climate conditions, etc.
- Procured equipment to address salt damage and conducted ongoing observation over time.
- Operated on test routes with a two-ton load, based on assumed passenger loads.
- Using local communication networks, accumulated data during trial runs to track the status of battery system operation.

## Prospects for Commercialization & Diffusion

With the 2017 opening of the Tan Vu-Lakh Hu yen Bridge linking Haiphong City and Cat Bai Island, an increase in bus demand on the island is expected, and the main company in Haiphong is expecting to increase its fleet to about 60 buses in around 2030.

- Step 1: Develop and test one demonstration bus with specifications for Cat Ba Island (this project)
- Step 2: Sell ten EV buses and photovoltaic systems to local route bus operators

## Applying the Technology Back in Japan

- In Japan, the use of EVs is still at its early stages, but the number of EVs on the road is steadily growing and expected to rise significantly in the future. Therefore, the technologies and knowhow gained from this demonstration project are expected to be applied in Japan.

## Financing Programme to Demonstrate Advanced Low-Carbon Technology Innovation for Further Deployment in Developing Countries

<b>Country</b>	Republic of Indonesia
<b>Project</b>	Energy saving for the de-greasing process of aluminum chips by utilization of superheated steam
<b>Company</b>	Giko Corporation
<b>Period</b>	FY2015 - FY2016

### Outline of Project

#### [Purpose]

- For the degreasing process (pretreatment for melting) of aluminum chips in Indonesia, a plant renovation was done to install equipment developed in Japan (manufactured by CYC Corporation) that has a solid track record as carbonization equipment for the treatment of valuable metals and organic materials. The aim is to improve efficiency and reduce costs through the renovation, and to reduce CO<sub>2</sub> emissions by reducing LNG consumption.
- Carbonization equipment made by CYC Corporation (Japan) was installed at Factory No. 2 of PT. Gikoko Kogyo Indonesia. The demonstration was conducted in Indonesia to assess the benefits after renovation by comparing existing equipment with the new equipment, and to assess performance of new equipment using aluminum chips produced in Indonesia.

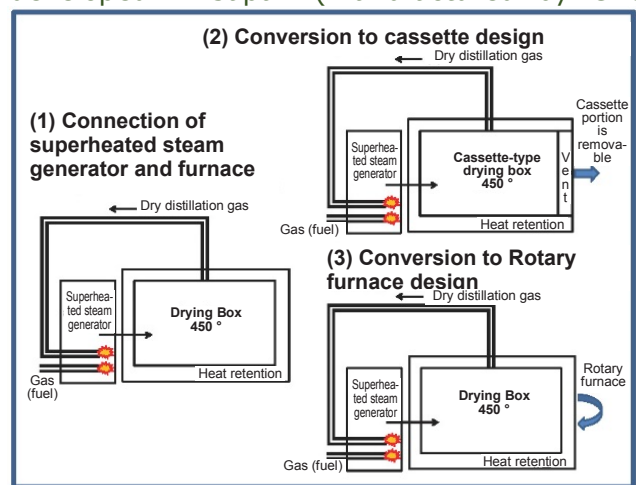

**Outline of demonstration project**

#### [Details of Tech. Renovation & Demonstration]

- (1) Connect the superheated steam generator and furnace to better utilize the superheated steam from high-efficiency CYC carbonization equipment. Eventually, install superheated steam generator internally.
- (2) Convert furnace to cassette-type design to reduce heat and operating time losses for furnace cooling (for small-scale plants).
- (3) Convert to rotary furnace to increase processing capacity (for medium-scale plants).
- (4) Reduce costs by controlling the processes at a lower temperature range, enabling conversion to use of steel in equipment.

### Outline of Target Country/Region

- There is a need to recycle chips produced in aluminum processing in Indonesia. Aluminum chips are typically being dried by directly heating with burners, but that approach has caused problems such as insufficient drying resulting in black smoke, reduced yields due to oxidation, and the generation of dross (residue after melting).
- A demonstration using actual chips was performed at Factory No. 2 of PT. Gikoko Kogyo Indonesia in the Jakarta region (Bogor), where a large quantity of aluminum chips has been generated.

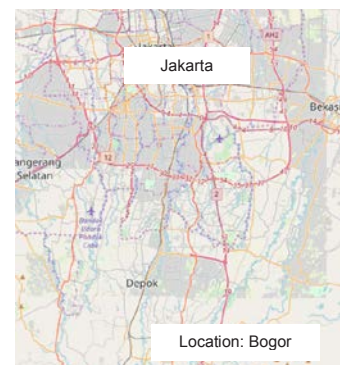

Map data© OpenStreetMap contributors  
www.openstreetmap.org/copyright



## Local Technology Needs

- A Japanese-made carbonization furnace was installed on a trial basis in around 2015. Test processing was done for aluminum chip degreasing, medical waste disposal, diaper processing, recovered metal, and coating/painting apparatus, etc. Positive results were obtained.
- However, economic factors such as facility costs, processing capacity, fuel efficiency, etc., were discouraging further adoption of the technology.
- There are significant economic benefits of applying carbonizing furnace technology to aluminum chip degreasing, but insufficient drying of chips resulted in black smoke, combustion losses, deterioration of melting furnaces, etc.



Aluminum chips (L) Carbonization furnace (R)

## Key Points of Technology Renovation

- To dry aluminum chips efficiently and in large quantities and further reduce furnace-related costs, the following were done: (1) optimized the quantity of superheated steam used, (2) optimized the materials used to make the furnace, (3) converted to cassette design to increase furnace operating time, (4) converted to rotary furnace to increase processing capacity.
- (1) Installing the superheated steam generator internally provided the required amount of superheated steam from the existing heating furnace burner, eliminating need for an external boiler, and significantly reducing fuel consumption.
  - (2) Installing the superheated steam generator internally enabled the use of lower heating furnace temperatures and replacement of refractory bricks with metal, reducing equipment costs and increasing thermal efficiency due to shorter start-up times.
  - (3) Previously, for safe operation it was necessary to wait until the carbonization chamber cooled before removing the contents, and the furnace could not be operated during that time. Changing to a cassette design (separating the carbonization chamber from the heating furnace) eliminated the heating furnace cooling process, leading to increased thermal efficiency.
  - (4) Use of rotary design increased heating surface area, leading to improved fuel efficiency and processing capacity.

### Complete carbonization with zero smoke!

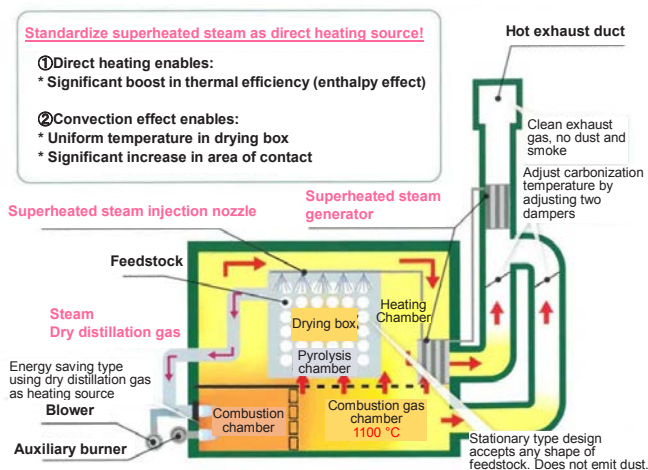

Outline of demonstration system



300 kg/h continuous aluminum chip degreasing furnace

## Results of the Project

### Summary of Results

- External boiler could be eliminated by installing a superheated steam generator in the combustion chamber.

- By converting to cassette design, the carbonization chamber could be separated from the heating furnace, which could then be sealed. Thermal efficiency was improved by eliminating the need to cool the heating furnace.
- Fuel efficiency of the heat drying process was significantly improved by converting to rotary furnace.

### **Prospects for Commercialization & Diffusion**

The automobile, motorcycle and other industries are expected to continue with high growth, considering overall growth in ASEAN countries. Demand for aluminum chip processing is expected to increase steadily until 2030.

- Step 1: Expand aluminum chip processing (plan: process 3,000 tons/month in 2020)
- Step 2: Expand beyond aluminum chip processing (used electrical cable, coating/painting apparatus, waste materials, etc.)

### **Applying the Technology Back in Japan**

- Japan has advanced technology for aluminum chip compression and briquette making in terms of (1) efficient use of space, (2) reduced transportation costs, (3) recovery/reuse of cutting oil. However, it is difficult to process briquette-shaped aluminum in conventional rotary kiln drying furnaces due to concerns about damage to kilns from briquettes impacting on the kilns due to rotation, as well as both cost and technical constraints due to the need for larger kilns because more time is required to degrease briquettes.
- The vertical cassette type furnace that is one of the achievements of this project is a stationary furnace, and is capable of degreasing aluminum chips and providing the same quality as furnaces that are being used in Japan. It has also achieved energy savings relative to the amount of material processed, and improved the processing capacity per furnace. Therefore, the vertical cassette type furnace is expected to be introduced and spread in the Japanese market.

## Financing Programme to Demonstrate Advanced Low-Carbon Technology Innovation for Further Deployment in Developing Countries

<b>Country</b>	Republic of the Philippines
<b>Project</b>	Establishment of bioethanol production system by utilizing unused biomass
<b>Company</b>	Nippon Steel & Sumikin Engineering Co., Ltd. (Project Participants: Japan International Research Center for Agricultural Sciences, NSEBIO Co., Ltd.)
<b>Period</b>	FY2015-FY2017

### Outline of Project

#### 【Purpose】

- The aim was to reduce CO<sub>2</sub> emissions in Southeast Asia by producing bioethanol from feedstock of unused cellulosic biomass and using the bioethanol as a substitute for gasoline. Create a system to produce cellulosic ethanol, utilizing otherwise unused materials such as sugarcane bagasse as feedstock, renovate equipment and demonstrate the entire process including ethanol conversion technology and the use of byproducts.
- Establish the component technologies in Japan, and conduct a demonstration in the Philippines for local adaptation of the system, from feedstock procurement to ethanol production and effective use of residues.

#### 【Details of Technology Renovation & Demonstration】

- (1) Renovation of ethanol manufacturing technology suitable for local feedstock
- (2) Demonstration test of cellulosic ethanol production technology (demonstration of pretreatment, saccharification, fermentation conducted in the Philippines)
- (3) Demonstration test of the impacts of using agricultural residue on soil fertility and fertilization effect of using ethanol residue and waste liquid.

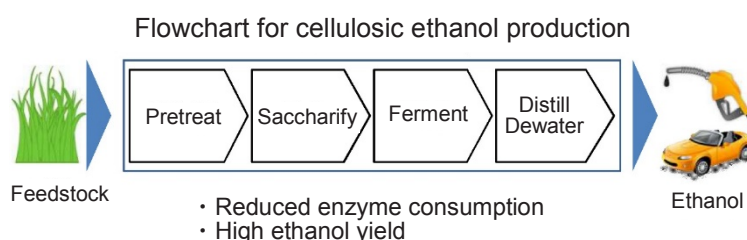

#### Outline of demonstration project

### Outline of Target Country/Region

- The blending of biofuels into gasoline has been mandatory in the Philippines since 2007. E10 gasoline blended with 10% ethanol has been on the market since 2011. The target is E20 to be achieved in 2020, but due to a major shortage of domestically-produced bioethanol, the shortfall is being imported.
- The country has an active sugar manufacturing industry, so there are many potential sources of cellulosic biomass, such as sugarcane bagasse and agricultural residue such as stalks and leaves.

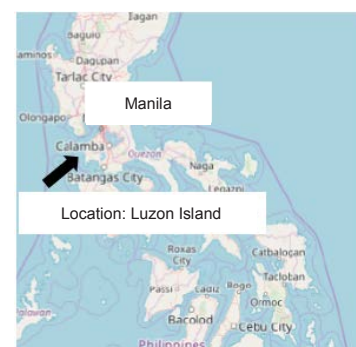

Map data © OpenStreetMap contributors  
www.openstreetmap.org/copyright

### Local Technology Needs

- The Philippine government promotes domestic procurement of bioethanol and requires oil refineries to preferentially purchase domestic bioethanol, but the country depends on imports.
- Cellulosic biomass such as agricultural residue as well as bagasse left over from sugar factories are available in significant quantities, so their effective utilization was desired.

## Key Points of Technology Renovation

### (1) Ethanol Production Technology Adapted to Local Feedstock

- Losses were halved by recovering the loss portion of fine-grained biomass from pretreatment process and re-injecting into the process. Volatilization loss portion significantly reduced by optimizing heating and other conditions.
- Identified causes of contamination loss from bacteria in fermentation process, and improved fermentation yield by reducing contamination.

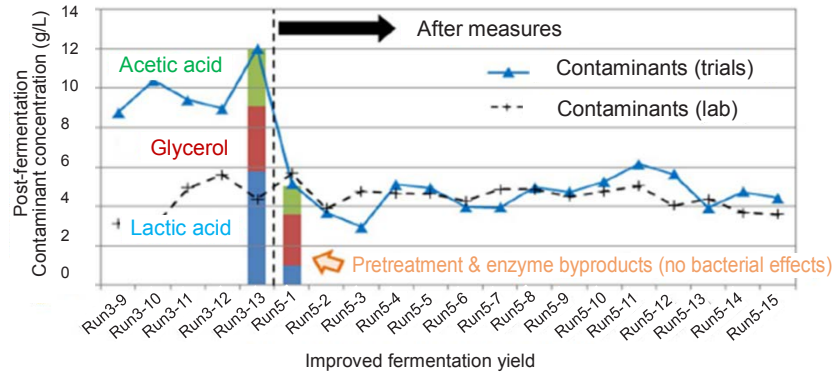

Post-fermentation contaminant concentrations before/after measures

### (2) Demonstration Test of Cellulosic Ethanol Production Technology

- For ethanol yields, the target of 250 liters/dry ton of fresh feedstock was achieved, close to levels that have been achieved in Japan.
- In addition to bagasse, trials with local grasses confirmed that ethanol yields similar to bagasse can be achieved by adjusting the pre-processing and pretreatment for differences in properties and ingredients compared to bagasse.

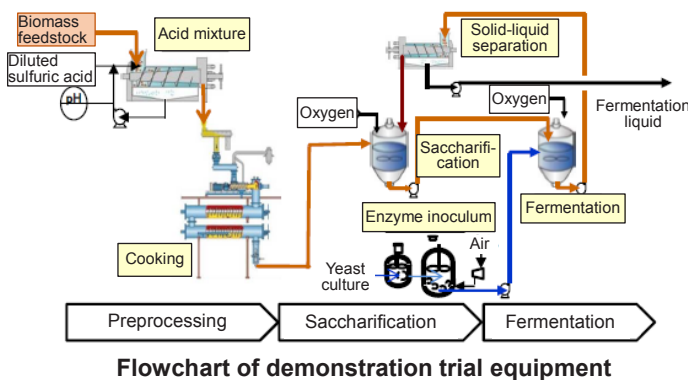
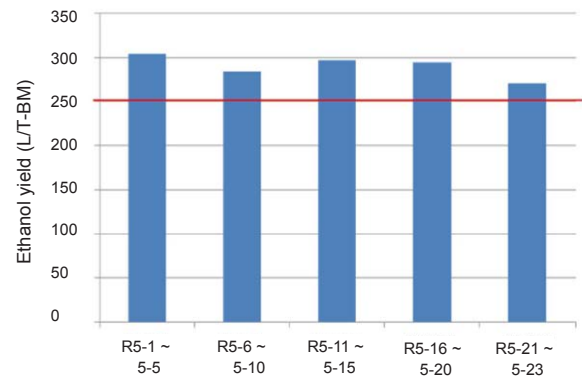

Flowchart of demonstration trial equipment

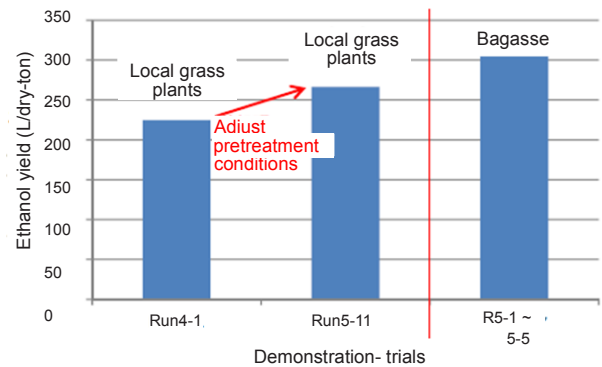

Demonstration trial results for ethanol

## Results of the Project

### Summary of Results

- Established component technologies (pretreatment, saccharification, fermentation) compatible for feedstock being used.
- Implemented trials with bagasse, agricultural residue, and local grasses as feedstock, and achieved the original target of 250 liters per dry ton.
- Confirmed that removing agricultural residue from farmland does not affect sugarcane growing.

## Prospects for Commercialization & Diffusion

- The Philippines requires gasoline to include a blend of bioethanol, with a preference for domestically-produced ethanol. Current domestic bioethanol production is based on first-generation feedstock (derived from non-cellulosic material), but it only meets about 1/3 of demand. The lack of supply is expected to continue, so there is a major need for cellulosic ethanol production.
- The plan is to start a cellulosic ethanol production plant construction business after the end of the subsidized project.
- This is expected to expand into sales of plants to companies that have access to a supply of feedstock, including sugar manufacturers and ethanol companies.

## Applying the Technology Back in Japan

- The results of this project are expected to be applied for the introduction of next-generation biofuels currently being studied in Japan (domestically produced ethanol from non-edible feedstock).
- The results of renovation in this project can be applied to other feedstocks, and can probably be applied to bio-derived products other than ethanol by developing pretreatment and saccharification technologies for cellulosic biomass.



## Financing Programme to Demonstrate Advanced Low-Carbon Technology Innovation for Further Deployment in Developing Countries

<b>Country</b>	Republic of Indonesia
<b>Project</b>	Low-head micro-hydro turbine power generation system for Indonesia cellular base transceiver stations
<b>Company</b>	Sinfonia Technology Co., Ltd.
<b>Period</b>	FY2015 – FY2016

### Outline of Project

#### [Purpose]

- The aim of this project was to reduce CO<sub>2</sub> emissions by renovating a micro-hydro power generation system with a propeller-type turbine, suited to sites with low hydraulic head, as an alternative to diesel generators being used as a power source for mobile phone base stations in off-grid areas of Indonesia.
- The demonstration was conducted in Indonesia to test the micro-hydro system's operation with specifications suited to the local environment and water quality, etc.

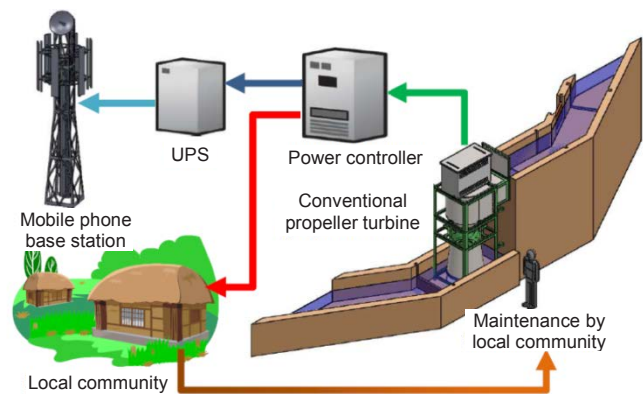

Outline of demonstration project

#### [Details of Technology Renovation & Demonstration]

- (1) Reduce costs and improve durability by simplifying the turbine design.
- (2) Demonstrate high efficiency power generation.
- (3) Create a design with reduced use of concrete.

### Outline of Target Country/Region

- There are over 10,000 mobile phone base stations in off-grid areas of Indonesia. Approx. 13,000 liters of diesel fuel is consumed annually per station to generate electricity for these stations.
- To put micro-hydropower generation to work as a future power source for mobile phone base stations, this project demonstrated technology remodeled to local specifications in Minggir, Sleman District, Yogyakarta Special Region. This is a rural area with many agricultural irrigation channels. Micro-hydro equipment has been installed in the past, but in some cases it has been removed due to insufficient head and other issues.

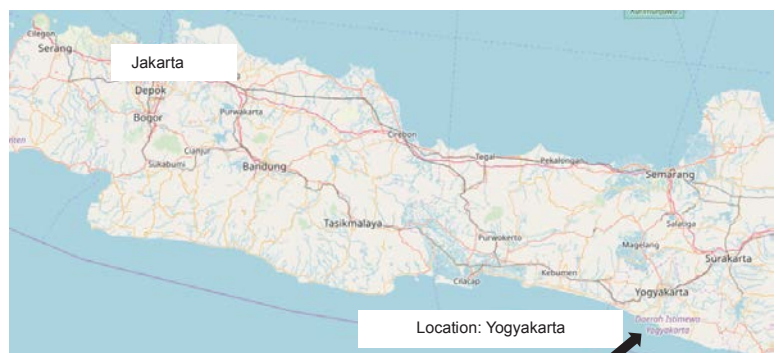

Map data © OpenStreetMap contributors  
www.openstreetmap.org/copyright

### Local Technology Needs

- Micro-hydropower has been introduced as a decentralized power source in Indonesia, but the technology has not spread widely due to operational problems. Major factors include (1) poor quality of concrete construction, and damage to concrete structures due to heavy rains, (2) the types of turbines used in Indonesia require a minimum head of 5 m, which limits the options for

installation sites, (3) debris gets caught in the guide vanes, fouling operations, and (4) lack of proper maintenance.

- It is expected to apply micro-hydropower technology that is small in size with small concrete structures and that can efficiently generate electricity even with a low hydraulic head, as an electrical power source for mobile phone base stations (cellular base transceiver stations) in off-grid areas that also have plenty of water channels.

## Key Points of Technology Renovation

In the demonstration, a 10 kW propeller-type water turbine was connected to a power controller to supply electricity to a nearby village. Propeller-type turbines are well-suited to low-head applications, and the Kaplan turbine with variable-pitch propeller blades and guide vanes is a technology already being used in Japan. However, for this project, considering local parameters, it was decided to simplify the design to reduce costs and at the same time improve ease of maintenance as well as durability.

### (1) Reduced cost and improved durability by simplifying the water turbine design

- Propellers and guide vanes were changed from the conventional variable design to fixed design. The fixed design was further optimized to achieve high efficiency, and durability was improved by simplifying the turbine design.
- The main body of the turbine was designed to be disassembled, which makes it possible to transport and install even in remote locations without good roads.
- This project included cooperation with a local turbine manufacturer with an eye to the local market, and an effort was made to improve the manufacturer's quality control systems.

### (2) Demonstration of high efficiency power generation

- By equipping the unit with a Japanese-made high-efficiency generator, high-efficiency was achieved in the field demonstration (increased from 89% by local generators to 97%).

### (3) Achieved design with less concrete

- By switching to a low-head hydropower system which does not require the type of concrete channels that would be required for high-head turbines, the design requires much less concrete. Also, by designing a system that can be installed outdoors, the housing around the turbine body could be eliminated.

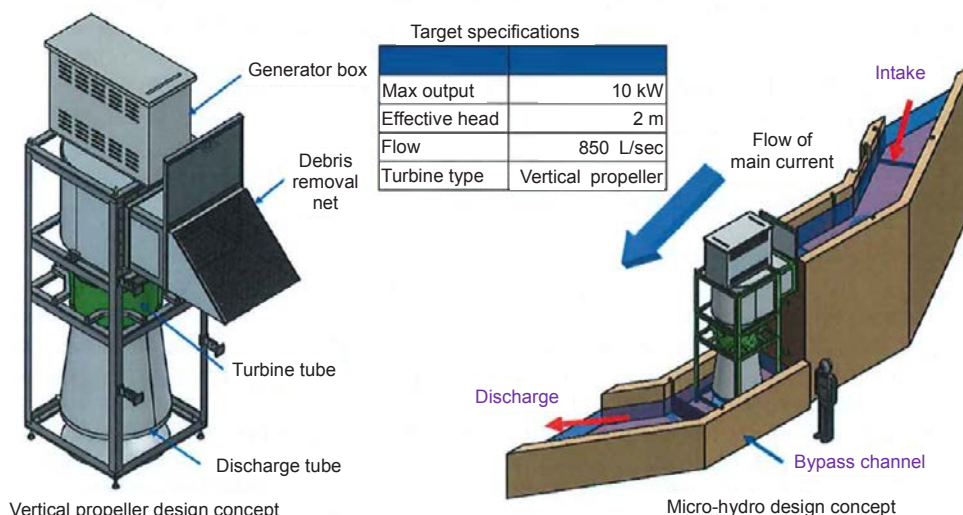

Design concept of low-head micro-hydro power generation system with propeller turbine

## Results of the Project

### Summary of Results

- An effort was made to reduce costs and improve durability by simplifying the design, including a switch from the conventional variable to fixed propellers and guide vanes. The main turbine unit

- was redesigned to allow it to be disassembled, making it easier to transport to remote locations.
- By equipping the unit with a high-efficiency generator, the generation efficiency increased from the conventional 89% to 97%.
- The design was also modified to operate at sites with a low head, and for outdoor installation, and to minimize the use of concrete structures.

### **Prospects for Commercialization & Diffusion**

Hydropower potential tends to be high in northern Sulawesi Island, in central Sumatra Island, in the Maluku Islands (Moluccas), and in Papua Province, etc. Electrification rates are low in these areas, so there is good potential there to generate electricity from hydropower.

- Step 1: Partnerships with Indonesian mobile phone power suppliers
- Step 2: Sales to Indonesian mobile phone communication companies
- Step 3: Sales to regional governments (villages that currently have little or no electrification)

### **Applying the Technology Back in Japan**

- There is high demand in Japan for micro-hydropower in low-head applications, including agricultural water, so these design approaches are expected to be applied back in Japan to reduce costs and improve durability.

## Financing Programme to Demonstrate Advanced Low-Carbon Technology Innovation for Further Deployment in Developing Countries

<b>Country</b>	Republic of the Union of Myanmar
<b>Project</b>	Development of rice husk gasification CHP system
<b>Company</b>	Yanmar Co., Ltd.
<b>Period</b>	FY2015 - FY2017

### Outline of Project

#### [Purpose]

- The aim was to reduce CO<sub>2</sub> emissions by using a gasification combined heat and power (CHP, also referred to as cogeneration) system that utilizes rice husks as feedstock to generate a stable source of electricity for rice mills.
- Also, to achieve energy savings and cost reductions by renovation of existing Japanese systems to process loose rice husks (not pellets) and automate the operations. An additional aim was to promote the technology by installing and demonstrating this system (see image on right) in Myanmar, where wastewater treatment is becoming a growing environmental concern.
- It is difficult to obtain sufficient quantities of long-grain rice husks in Japan for demonstration. Also, Japan and Myanmar use different actors for each process of rice production and the processes of the equipment that produce rice husks are also different. For these reasons the demonstration was done in Myanmar.

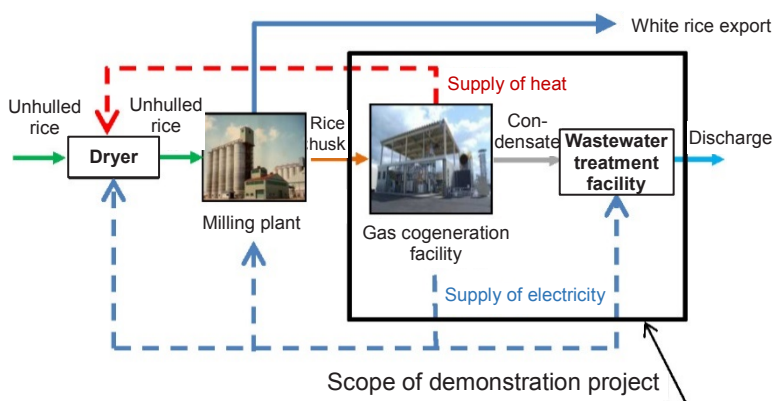

**Outline of demonstration project**

#### [Details of Technology Renovation & Demonstration]

- (1) Rice husk gasification CHP technology to convert rice husks into energy and supply electricity and heat
- (2) Technology to treat condensate produced by rice husk gasification CHP equipment

### Outline of Target Country/Region

- In Myanmar, the economy is based on the agricultural sector and top priorities include agricultural promotion and increasing rice production.
- Electricity demand is increasing along with economic growth, but the national electrification rate is only about 31% and there are chronic shortages of electricity. The electrical grid is most developed in urban areas. As a result, the electricity supply is not keeping up with the needs of rice mills.

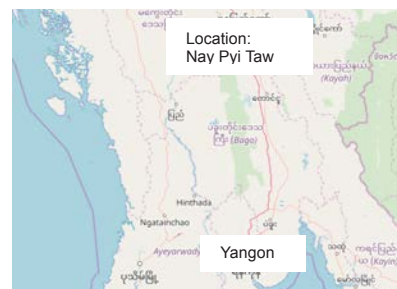

Map data © OpenStreetMap contributors  
www.openstreetmap.org/copyright

### Local Technology Needs

- Myanmar has many small rice mills that process below 100 tons/day, many of which are powered by generators driven by diesel fuel or rice husk gasification. However, existing rice husk gasification power generation equipment causes environmental issues relating to wastewater treatment, etc., and there are also problems with the disposal of large volumes of rice husks, so there is a desire to address these issues.



## Key Points of Technology Renovation

### (1) Technology for rice husk gasification CHP to convert rice husks to energy and supply electricity and heat

- Succeeded in gasification by suppressing the formation of crystalline silica by using loose rice husks. Verified that the technology can be used for both short-grain rice husks (Japan) and long-grain rice husks (Myanmar).
- Uniform gasification at high temperatures reduces tar concentrations and resulted in stable operations.

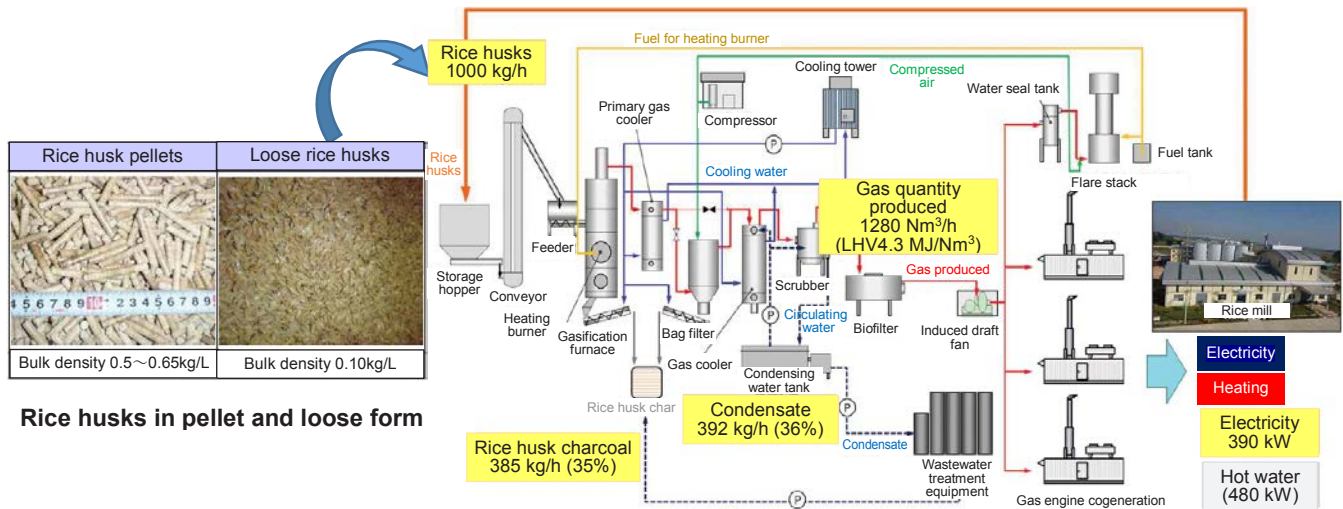

Demonstration facility flowchart and material flows

### (2) Technology for treatment of condensate from rice husk gasification CHP equipment

- Achieved target water quality guideline values for most parameters. Suspended solids that exceed guideline values can be removed by sand filtration. Also ammonia (in condensate) that exceeds guideline values can be used as an effective ingredient for fertilizer, and rice husk charcoal is a residue of the gasification process. Using the condensate as a quenching spray can simplify the condensate treatment process at the same time as increasing the fertilizer value of the rice husk charcoal.
- Based on the achievements with (1) and (2) above, this project demonstrated a low tar gasification and circulating-type gas processing system that does not require additional water, and a wastewater treatment system that reduces the amount of wastewater generated by using only condensate for gas cooling. In addition, this project confirmed that because only a small volume of treated water is produced from condensate, it is possible to return it to the soil by spraying the treated water on the rice husk charcoal.

## Results of the Project

### Summary of Results

- (1) Achieved stable operation of gasification CHP system utilizing rice husks.
- (2) Confirmed that water treatment can be simplified by spraying treated water onto rice husk charcoal in order to utilize the ammonia in condensate.

### Prospects for Commercialization & Diffusion

There is potential to utilize the fertilizer effect of rice husk charcoal (one of the residues from rice husk gasification CHP equipment) and contribute to the energy and agricultural sectors through "tri-generation" (electricity, heat, and rice husk charcoal).

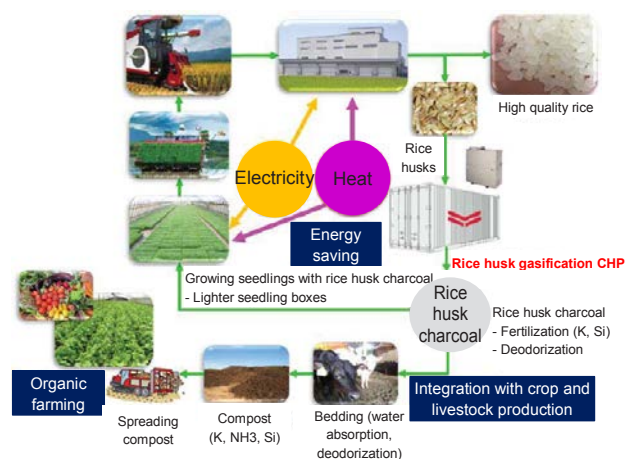

Concept design of tri-generation (electricity, heat, rice husk) charcoal



- Step 1: Partner/cooperate with local companies operating rice mills.
- Step 2: Partner with local engineering and manufacturing companies.
- Step 3: Expand to other countries.

### **Applying the Technology Back in Japan**

- The development of compact rice husk gasification CHP units leads to expectations that improvements of operational rates to match the volume of rice husks available and the promotion of tri-generation will be applied back in Japan.

## Financing Programme to Demonstrate Advanced Low-Carbon Technology Innovation for Further Deployment in Developing Countries

<b>Country</b>	United Republic of Tanzania
<b>Project</b>	Electricity retail service at kiosks in off-grid areas
<b>Company</b>	WASSHA Inc. (Project Participant: myclimate Japan Co., Ltd.)
<b>Period</b>	FY2015 – FY2016

### Outline of Project

#### 【Purpose】

- This project provides a charging service at kiosks in off-grid areas in Tanzania using the WASSHA System, which includes four components: a smartphone application (app), a small-scale photovoltaic panel array, chargers, and storage batteries. The aim was to reduce CO<sub>2</sub> emissions by reducing the amount electricity generated from diesel generators, which is commonly used in off-grid areas.
- Renovating chargers to enable metered sales of electricity and renovating the smartphone app to control the chargers creates a new system for electricity use that is compatible with local lifestyles.
- The system demonstration is done in Tanzania in a local social environment that differs from Japan in terms of the needs for access to electricity and mobile phone payment systems, etc.

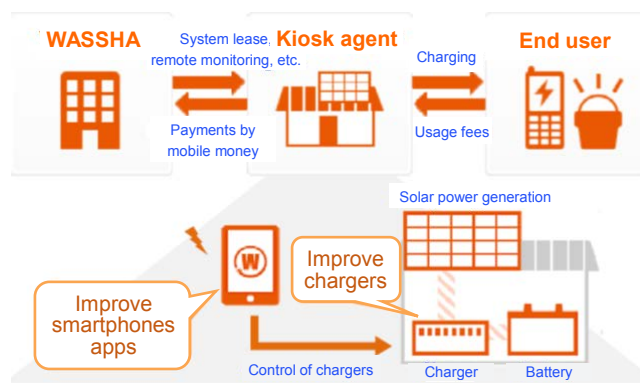

**Outline of demonstration project**

#### 【Details of Technology Renovation & Demonstration】

- (1) Improvement of charger to match local user environment
- (2) Improvement of user interface and smartphone app that controls the chargers
- (3) Demonstration of a charging service using a solar photovoltaic system and storage batteries compatible with the local climate

### Outline of Target Country/Region

- In Tanzania, the rural electrification rate is very low, and rural population density is also low, so the cost-effectiveness of building an electrical grid to cover every part of the country is prohibitive. As a result, rather than connecting to a power grid, there are many stand-alone power sources on a local, village or household basis, including mini-grids, solar home systems, and charging stations, etc.
- The penetration rate of mobile phones is high at 70%, and mobile payment services are growing rapidly.

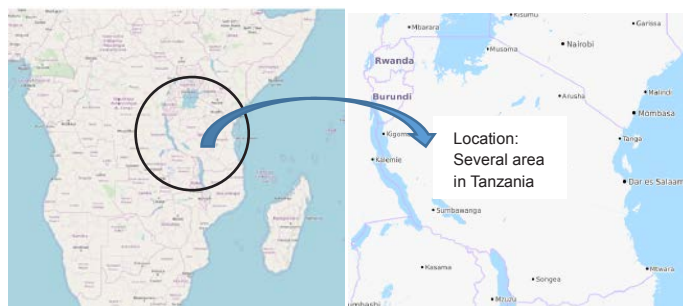

Map data© OpenStreetMap contributors  
www.openstreetmap.org/copyright

### Local Technology Needs

- In off-grid areas, household lighting is the top electricity consumer, followed by mobile phone charging.
- Kerosene lamps cause health risks due to soot and smoke, and kerosene fuel is expensive. Meanwhile, LED lanterns with solar panels are also expensive, so their use is limited.
- People living in off-grid areas have limited access to banks, so mobile phone payment services

are spreading rapidly, which expands the need for mobile phone charging services. There is strong demand for easily accessible (e.g., at kiosks) charging services for mobile phones and lighting such as LED lanterns, etc.

## Key Points of Technology Renovation

### (1) System Design for Kiosk Charging Service with PV Panels

- In FY2016, the system was tested at 735 kiosks in 8 regions of Tanzania (75 to 100 kiosks per region), selected for their different regional characteristics.
- To use the charging service, a local user (A in the figure) visits a local kiosk and pays a charging fee to the kiosk agent (B), who has been issued "electricity purchase tickets" by WASSHA (D). The amount of tickets issued matches the amount of money remitted by a mobile phone remittance service to pay WASSHA (D). With a controller the agent then uses a smartphone to send WASSHA an electricity purchase ticket corresponding to the amount of electricity the user wants to use, and can sell electricity to the user from the WASSHA System (C).
- The WASSHA System is provided by a lease from WASSHA to the kiosk agents. They can centrally manage their customer information and sales data with a smartphone app that has been improved for greater convenience.



System for device charging service using photovoltaic panels at kiosks



A kiosk in Tanzania

### (2) Adapting the WASSHA System to the Local Market

- Based on field tests, charging device circuit boards were designed with internal protection circuits for overcurrent and battery pole reversal. Also, with mass production in mind, design specifications were set with one circuit board for charger devices, and two for charging.
- Improving the smartphone app's user interface, adding a charging service verification function, and including bonus to electricity purchase tickets, increased the incentive for kiosk agents to use the system, and usage fees increased.
- Many off-grid areas have weak signal reception and/or are offline, but can still use a short message service (SMS, i.e., texting), so the system was designed to handle electricity purchase tickets by SMS. This allows kiosk agents to provide charging services in these areas too.

With regard to the optimal scale of power generation and battery sets for local climate conditions, it was decided to design photovoltaic power generation at 150 W and storage batteries at 100 Ah. This was based on data gathered from the demonstration trials in terms of kiosk usage levels and remaining battery charges.



Charger works with USB cables

## Results of the Project

### Summary of Results

- Improved durability and usability of chargers, improved charging efficiency, lower costs.
- For the smartphone app, user-friendliness was improved, and changes were made to enable version updates even when offline.
- Demonstrated and evaluated the optimum combination of solar panels and storage batteries to be compatible with local climate conditions

## **Prospects for Commercialization & Diffusion**

- Commercialization efforts began in FY2017 and the number of users is increasing. Starting in FY2019, efforts will be made to start expanding to other countries in Asia and Africa.

## **Applying the Technology Back in Japan**

- During a disaster, power failures can often result in equipment such as lighting and communications devices such as mobile phones being unusable at evacuation centers. It can also be difficult to determine the status of evacuation centers around the region. There could be a high demand for charging of mobile phones and other devices using solar power, which can be used even in an unstable Internet environment, as well as a remote monitoring service such as a web dashboard that makes it possible to ascertain the status of individual evacuation centers. Therefore, this technology has some potential for introduction in Japan.

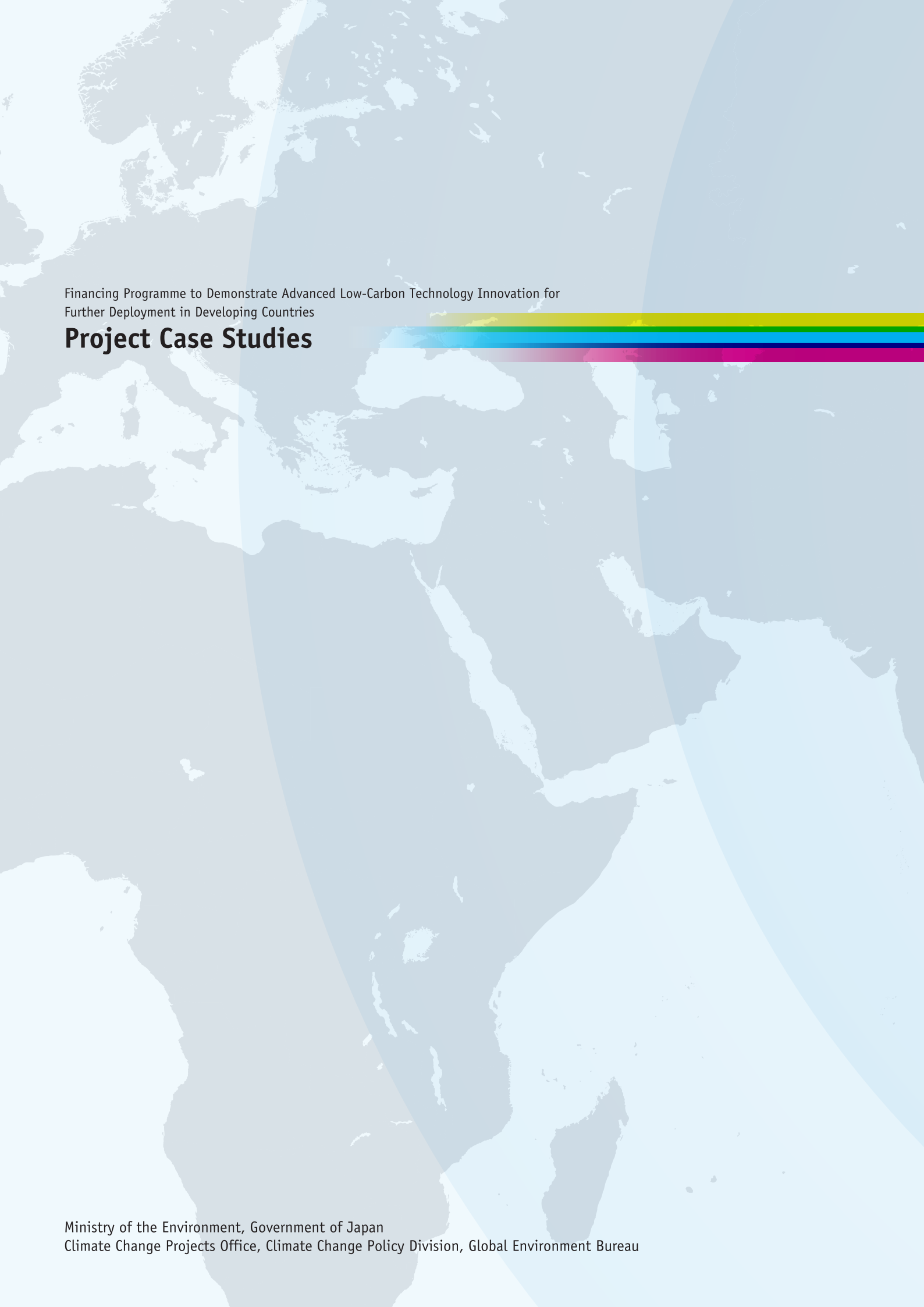

Financing Programme to Demonstrate Advanced Low-Carbon Technology Innovation for  
Further Deployment in Developing Countries

## **Project Case Studies**